

Tartu Infopäev – MAN bussid ja veokid



24. Jaanuar 2018



Hetkel kehtib Euro 6c, kohe rakendub Euro 6d

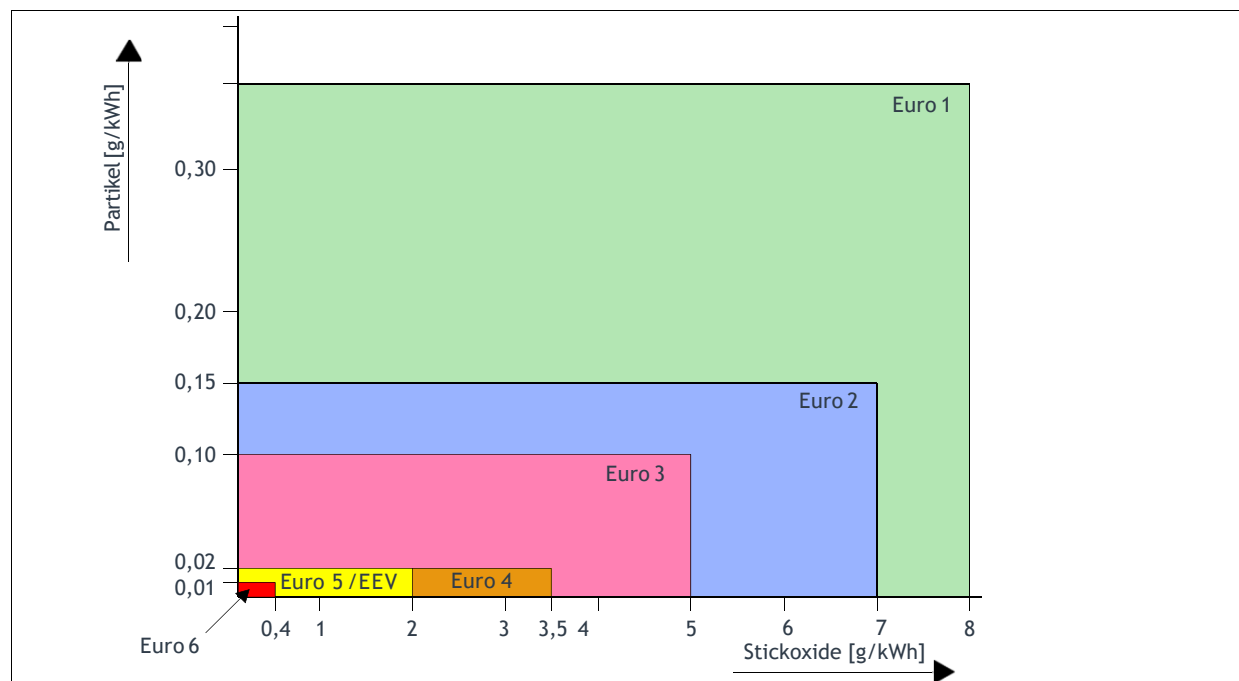

1993a. Euro 1 – 2001a. Euro 3 – 2009a. Euro 5 – 2013a. Euro 6

MAN bussid - maagaasimootoriga

Ajalugu: 75 aastat gaasi tehnoloogiat ja kogemust

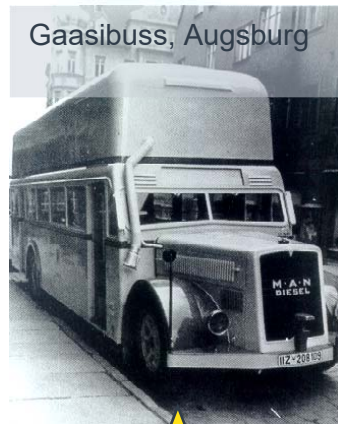

1943



1972

1992



2001





2009

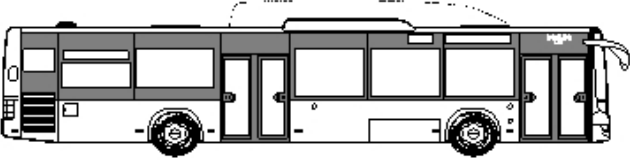

EEV mootori
esmaesitlus

MAN bussid Surugaasimootorigega

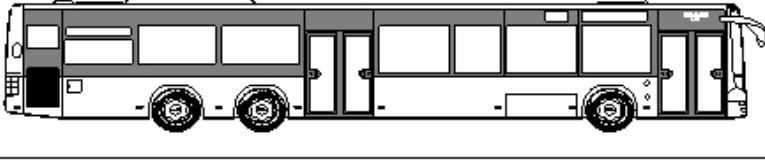

Modell	Länge	Höhe	Motorisierung
Lions' City 	12 m	3,30 m ¹⁾ 3,32 m ²⁾	E2876 LUH (R6, 12,8 l) <ul style="list-style-type: none"> ▪ 200 kW ; 1050 Nm ▪ 228 kW ; 1250 Nm
Lion's City Ü 	12 m	3,30 m ¹⁾ 3,32 m ²⁾	E2876 LUH (R6, 12,8 l) <ul style="list-style-type: none"> ▪ 200 kW ; 1050 Nm ▪ 228 kW ; 1250 Nm
Lion's City C/L 	13,70/14,70 m	3,30 m ¹⁾ 3,32 m ²⁾	E2876 LUH (R6, 12,8 l) <ul style="list-style-type: none"> ▪ 200 kW ; 1050 Nm ▪ 228 kW ; 1250 Nm
Lion's City G 	18 m	3,30 m ¹⁾ 3,32 m ²⁾	E2876 LUH (R6, 12,8 l) <ul style="list-style-type: none"> ▪ 228 kW ; 1250 Nm

Kõik mudelid nii täismadala kui Low Entry variandina

1) Dynetec- mahutid 1176 kuni 2050 L

2) Raufoss-mahutid 1284 kuni 1712 L

MAN surugaasimootorid

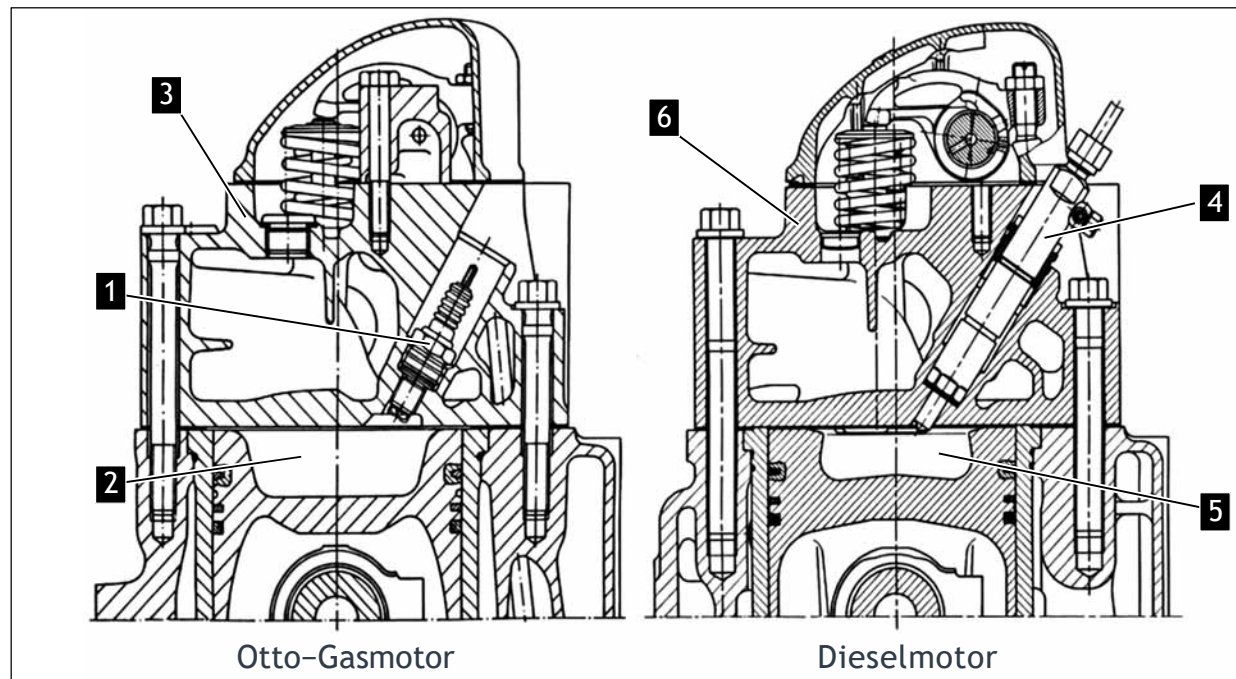

Võrdlus Otto- ja Diiselmootor

- 1. Kütüral
- 2. Põlemiskamber
- 3. Plokikaas

- 4. Pihusti
- 5. Põlemiskamber
- 6. Plokikaas

Otto vs diiselmootor

MAN surugaasimootorite areng



MAN surugaasimootorite areng alates 1990 aastast

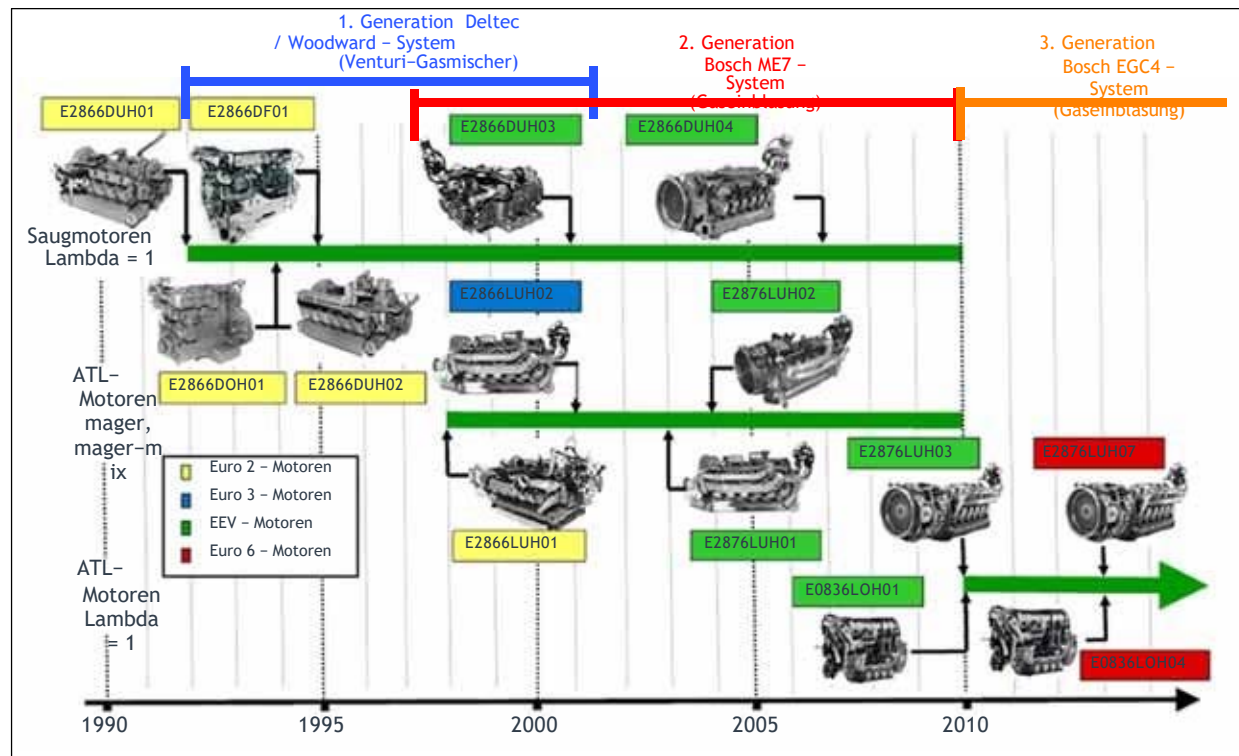

MAN surugaasimootorite areng

MAN Surugaasimootor E 2876 LUH

Parameetrid



Võimsuse kõver

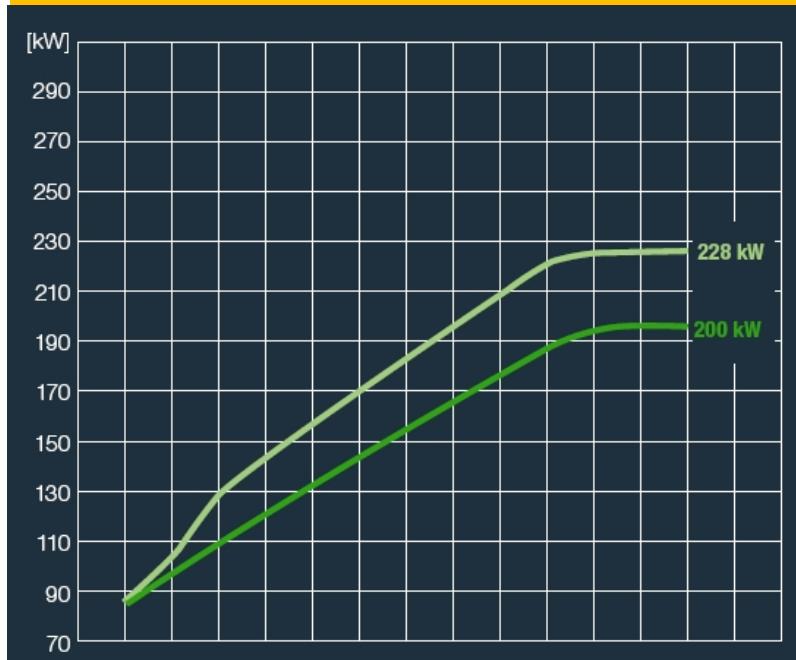

Pöördemomendi kõver

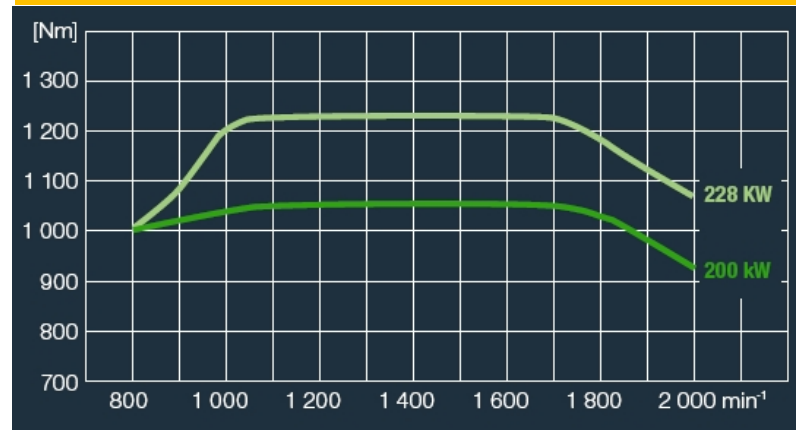

228 kW bei
2000 U/min
1250 Nm bei 1000
- 1700 U/min
EURO 6



Surugaasil töötavad MAN bussid

Heitgaaside saastenormid ja MAN Euro 6 mootorid

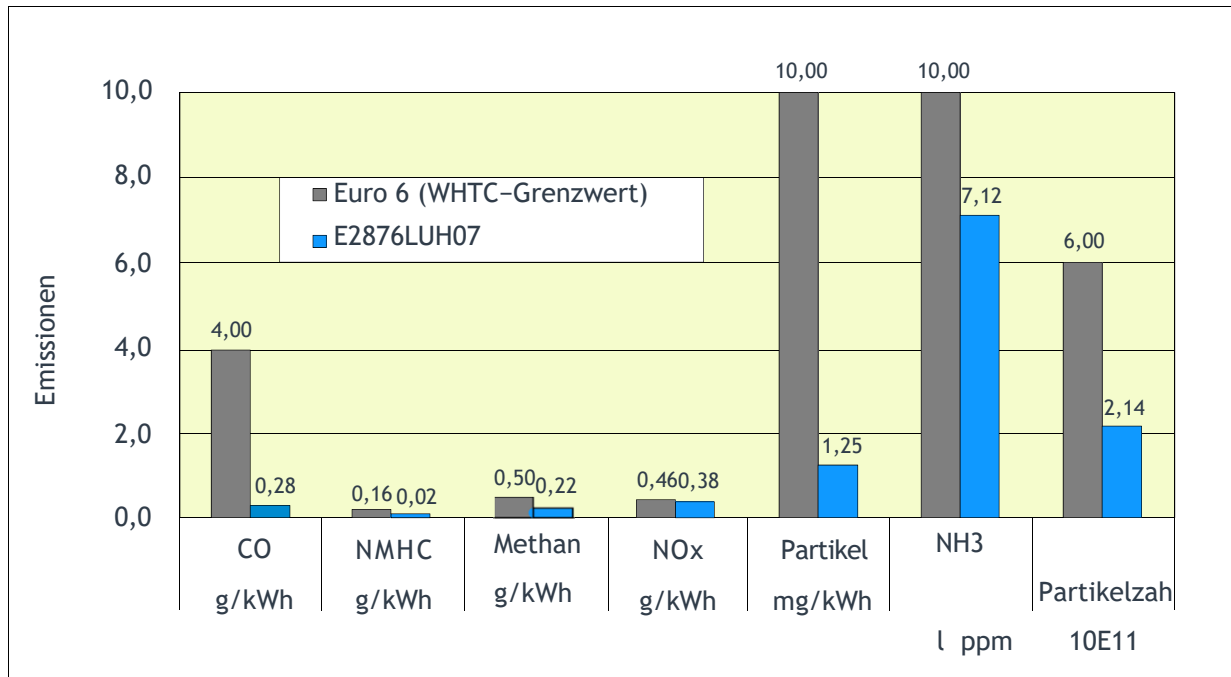

Gaasimootori saasteparameetrid EURO 6 WHTC testi piirväärtustega võrreldes:

CO 95% madalam saaste normatiivist
NMHC 99% madalam saaste normatiivist
NOx 27% madalam saaste normatiivist
Tahked osakesed 87% madalam saaste normatiivist

NB! Surugaasimootoriga bussi müratase kiirendusfaasi möödasõidul ainult 77dB.

CNG mahutid, tankimissüsteemid

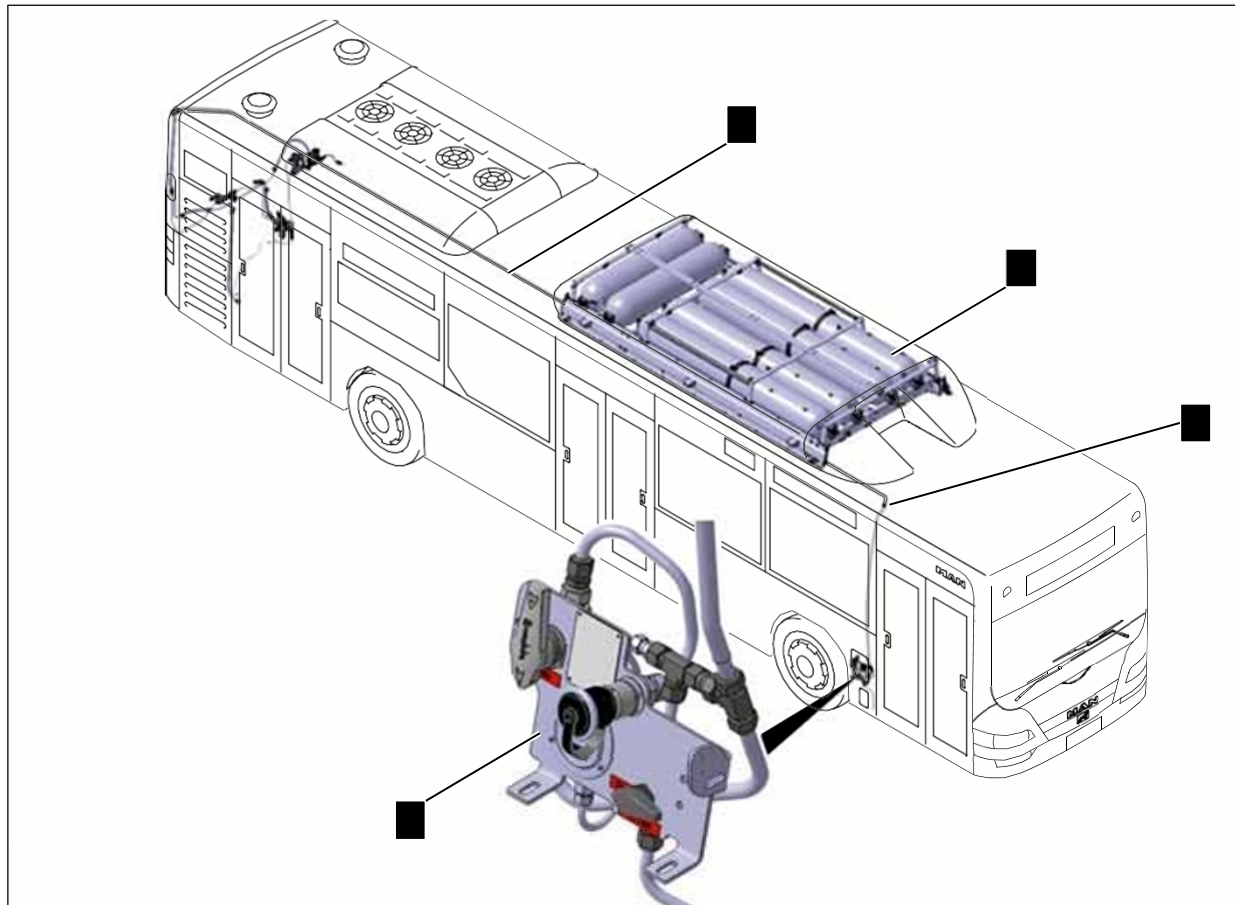

Hexagon Raufoss AS	Typ 4	EMER	8 x 214 L	1.712	ca. 885
		EMER	6 x 214 L	1.284	ca. 725

Kogu gaasivarustuse ja tankimissüsteem ECE-R 110 –le vastav.



Tankimine paremal

- .1. Tankimisot
- .2. CNG-mahutid
- .3. Torustik

Müük maailmas



Suurimad MAN surugaasibussidega opereerivad riigid:
(Türgi 2000, Rootsi 1300, Saksamaa 920)

CNG geograafia EU-s laieneb:

Ungari	75 tk 2016
Ljubljana	30 tk 2016
Madrid/Barceona	60 tk 2016
Tbilisi	143 tk 2016
Copenhagen	41 bio 2017
Porto	173 tk 2018-20
.....	
Eesti	32 tk kokku

Kokku tarnitud 2000-2016 üle **6400** bussi

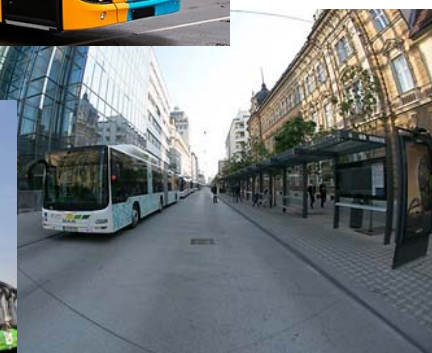

Madalapõhjaline MAN Lion's City CNG

Tarnitav 3. generatsiooni 270 või 310 hj Euro 6 turbomootoriga



- Euro 6 saaste standardile vastav madalapõhjaline linnaliinibuss
- 2 või 3 topeltlaia uksega, 80 – 90 reisijale

Esimene linnaliinibuss Tallinnas septembris 2009



Surugaasibusside tarded Eestisse



Tallinna Lennujaam
2012: 2 MAN Lion's
City linnaliinibussi



Maanteeameti hange
2013: Pärnu 2 ning Narva
5 MAN Lion's City
linnaliinibussi



Surugaasibusside tarded Eestisse



MRP Linna Liinid 2014: 7 MAN Lion's City GL liigendbussi Tallinnasse, 2017 lisandusid 11 täismadalat 12m linnaliini



Sebe lisas 2017 Tartu linna – liinidele 3 uut täismadalat 12m Lion's City linnaliini



MAN Lion's City GL CNG – BUS of the Year 2015 tiitliga pärjatud





Täna tähelepanu eest !